

Les vérins courses brèves peuvent être implantés facilement grâce à leur encombrement réduit:

- version avec ou sans piston magnétique
- version simple ou double effet.
- version tige traversante
- différentes natures de joints: NBR, POLYURETHANE ou FKM/FPM (pour haute température)
- version anti-rotation
- version avec fixation arrière intégrée
- versions spéciales sur demande



CARACTERISTIQUES TECHNIQUES	POLYURETHANE	NBR	FKM/FPM	Basse Temp.
Pression d'utilisation	max 10 bar (max 1 MPa)			
Température d'utilisation	-10°C à +80°C	-10°C à +80°C	-10°C à +150°C (version non magnétique)	-35°C à +80°C
Fluide	Air filtré lubrifié ou non			
Diamètres	Ø 12 ; Ø 16 ; Ø 20 ; Ø 25 ; Ø 32 ; Ø 40 ; Ø 50 ; Ø 63 ; Ø 80 ; Ø 100			
Type de construction	Tube profilé			
Courses standards +	Double effet: Ø 12 à Ø 25, course 5 à 50 mm Ø 32 à Ø 40, course 5 à 70 mm Ø 50 à Ø 63, course 5 à 110 mm Ø 80 à Ø 100, course 5 à 150 mm Simple effet: Ø 12 à Ø 25, course 5 à 25 mm Ø 32 à Ø 63, course 5 à 50 mm Anti-rotation: Ø 12 à Ø 63, course 5 à 120 mm Ø 80 à Ø 100, course 5 à 150 mm Tige trav. creuse: Ø 20 à Ø 40 course 5 à 100 mm Ø 50 à Ø 63 course 5 à 130 mm Ø 80 à Ø 100 course 5 à 165 mm			
Versions	Double effet, Double effet tige traversante, Simple effet tige rentrée, Simple effet tige traversante, Double effet tige traversante creuse, Anti-rotation, avec fixation arrière mâle, avec fixation arrière femelle			
Piston magnétique	Standard sur toutes les versions. Sur demande sans.			
Pression de décollement	Ø 12 à Ø 32: 0.6 bar - Ø 40 à Ø 100: 0.4 bar			
Effort à 6 bar poussée/traction	Voir CARACTERISTIQUES TECHNIQUES GENERALES PAGE 1.1/05			
Poids	Voir CARACTERISTIQUES TECHNIQUES GENERALES PAGE 1.1/06			
Nota	Pour les versions Basse vitesse utiliser uniquement de l'air non lubrifié			
+Courses maximum recommandées. Problèmes de fonctionnement pour des courses supérieures.				

COMPOSANTS

- ① TIGE: Acier chromé C40 ou inox
- ② FONDS:
Ø 12 ÷ 25 laiton - Ø 32 ÷ 100 aluminium
- ③ JOINT DE TIGE:
Ø 12 à 63 SFR (PARKER PRADIFA) NBR ou FKM/FPM
Ø 80 à 100 Polyuréthane (PARKER PRADIFA), NBR ou FKM/FPM
- ④ GUIDAGE DE TIGE: feuillard d'acier avec insert en bronze et PTFE
- ⑤ TUBE: aluminium profilé anodisé
- ⑥ PISTON:
Ø 12 à 63 résine acétale
Ø 80 à 100 aluminium avec patin de guidage en PTFE
- ⑦ JOINTS DE PISTON:
Ø 12 à 63 Polyuréthane (PARKER PRADIFA), NBR ou FKM/FPM
Ø 80 à 100 SFR (PARKER PRADIFA) NBR ou FKM/FPM
- ⑧ ANNEAU MAGNETIQUE:
Ø 12 à 25 néodymium - Ø 63 à 100 plastoférite
- ⑨ JOINTS O-ring: NBR ou FKM/FPM

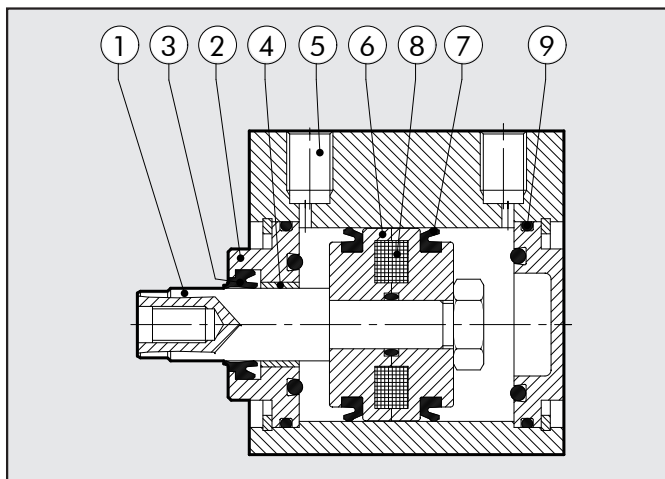

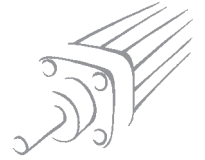

POSSIBILITE DE FIXATION DES VERINS SSCY

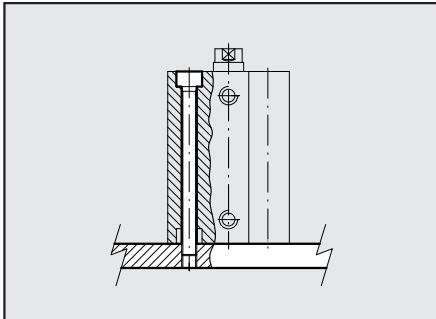

Fixation possible à travers le corps de vérin par vis ou tirants. Dans ce cas utiliser impérativement des vis ou tirants en inox amagnétique (Ex: AISI 304)

COTES D'ENCOMBREMENT VERSIONS STANDARDS

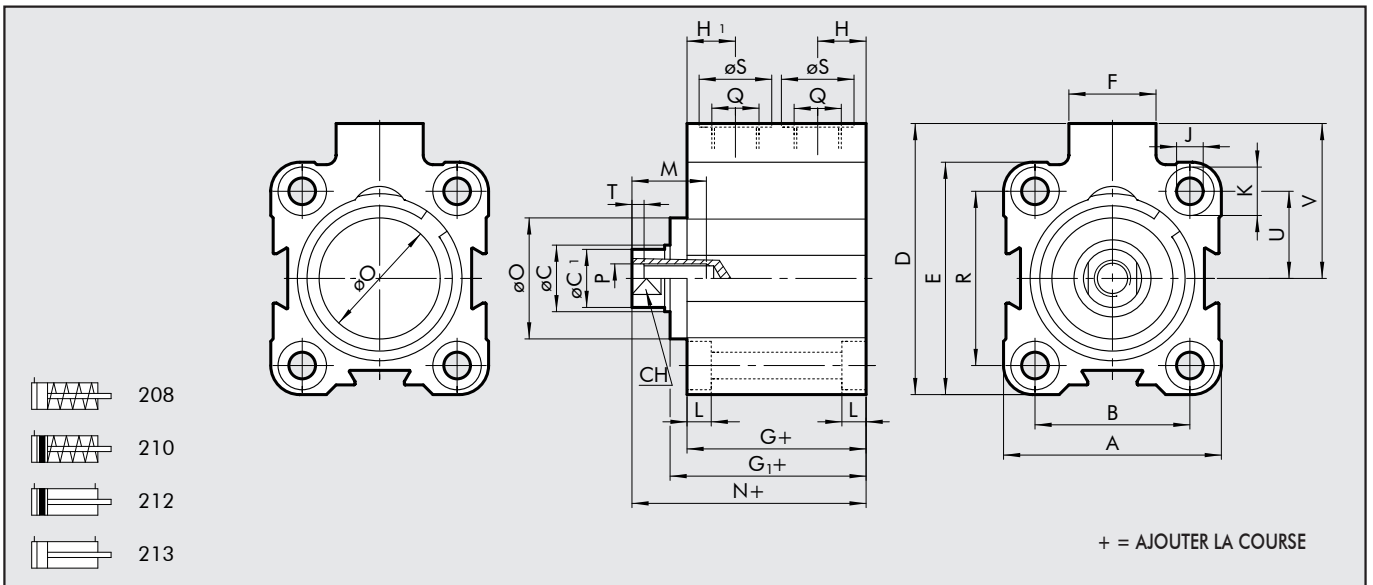

COTES D'ENCOMBREMENT VERSIONS DOUBLE EFFET

Ø	A	B	øC	øC ₁	D	E	F	G	G ₁	H	H ₁	J	K	L	M	N	øO	P	Q	R	øS	CH	T	U	V
12	23.5	13	6	5.5	28	26	11	32.5		6.5	10.5	3.7	6	3.7	7	38	M3	M5		8	5	2	9.5	16.5	
16	28	20	8	7.5	33	28	11	33		6.7	10.5	3.7	6	3.7	10	37.5	M5	M5	20	8	7	2	10	19	
20	32	22	10	9	37	32	11	32		6.5	10.5	4.6	7.5	4.6	10	36.5	M5	M5	22	8	8	2	11	21	
25	37	26	10	9	47.5	39	18	33	36.5	8.5	8.5	4.6	7.5	4.6	10	42.5	20	M5	G1/8	28	15	8	2	14	28
32	45	32	12	11	56	48	18	37	40.8	10	10	5.5	10	5.7	15	48.3	25	M6	G1/8	36	15	10	2.5	18	32
40	54.5	40	12	11	62.7	54.5	18	39.5	44.7	10	10	5.5	10	5.7	15	53.2	30	M6	G1/8	40	15	10	2.5	20	35.5
50	66	50	16	15	73	66	18	39.5	46.2	11	11	6.6	11	6.8	18	53.2	35	M8	G1/8	50	15	13	3.5	25	40
63	80	62	16	15	88	80	23	42	48.7	12	12	9	15	9	18	57.7	35	M8	G1/8	62	15	13	3.5	31	48
80	100	82	20	19	110	100	26	57	67.2	14	14	9	15	9	18	75.2	44	M10	G1/4	82	19	17	4	41	60
100	124	103	25	24	134	124	26	64	74.7	15	15	11	18	11	20	84.3	56	M12	G1/4	103	19	22	5	51.5	72

COTES D'ENCOMBREMENT VERSIONS SIMPLE EFFET TIGE RENTREE

Ø	course	A	B	øC	øC ₁	D	E	F	G	G ₁	H	H ₁	J	K	L	M	N	øO	P	Q	R	øS	CH	T	U	V
12	5÷25	23.5	13	6	5.5	28	26	11	32.5		6.5	10.5	3.7	6	3.7	7	38		M3	M5		8	5	2	9.5	16.5
16	5÷25	28	20	8	7.5	33	28	11	33		6.7	10.5	3.7	6	3.7	10	37.5		M5	M5	20	8	7	2	10	19
20	5÷25	32	22	10	9	37	32	11	32		6.5	10.5	4.6	7.5	4.6	10	36.5		M5	M5	22	8	8	2	11	21
25	5÷25	37	26	10	9	47.5	39	18	33	36.5	8.5	8.5	4.6	7.5	4.6	10	42.5	20	M5	G1/8	28	15	8	2	14	28
32	5÷25	45	32	12	11	56	48	18	37	40.8	10	10	5.5	10	5.7	15	48.3	25	M6	G1/8	36	15	10	2.5	18	32
	>25÷50								45	48.8							56.3									
40	5÷25	54.5	40	12	11	62.7	54.5	18	39.5	44.7	10	10	5.5	10	5.7	15	53.2	30	M6	G1/8	40	15	10	2.5	20	35.5
	>25÷50								47.5	52.7							61.2									
50	5÷25	66	50	16	15	73	66	18	39.5	46.2	11	11	6.6	11	6.8	18	53.2	35	M8	G1/8	50	15	13	3.5	25	40
	>25÷50								47.5	54.2							61.2									
63	5÷25	80	62	16	15	88	80	23	42	48.7	12	12	9	15	9	18	57.7	35	M8	G1/8	62	15	13	3.5	31	48
	>25÷50								50	56.7							65.7									

COTES D'ENCOMBREMENT VERSIONS SIMPLE EFFET TIGE SORTIE

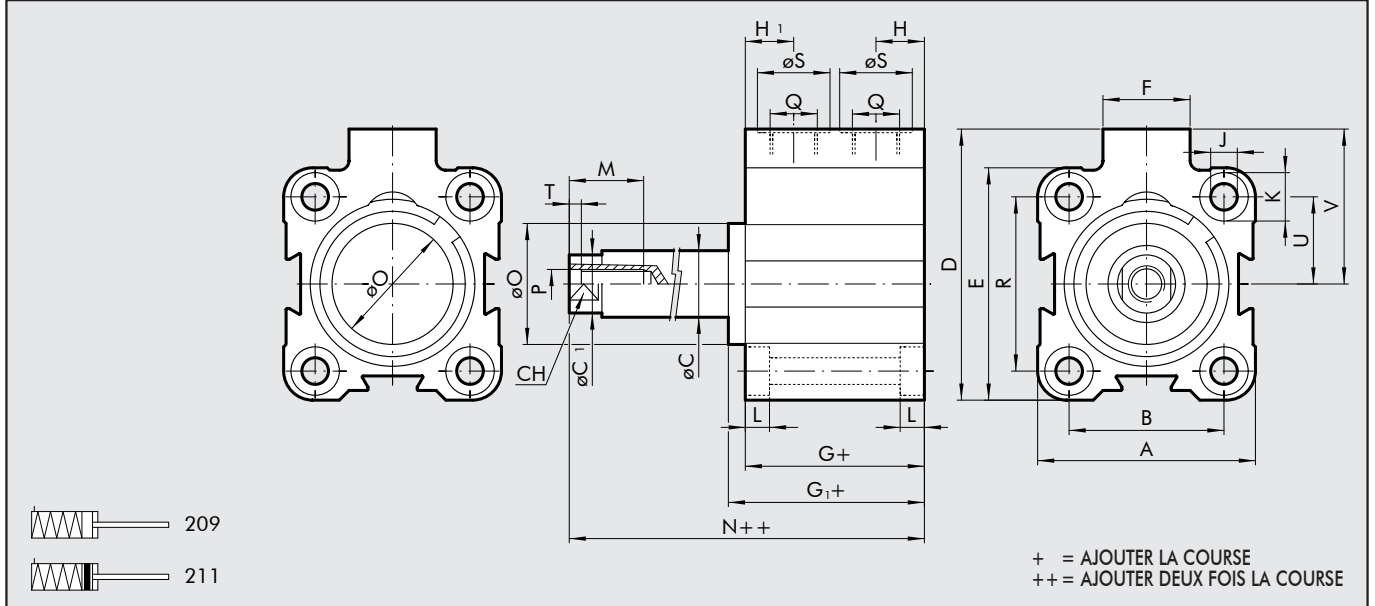

Ø	course	A	B	øC	øC ₁	D	E	F	G	G ₁	H	H ₁	J	K	L	M	N	øO	P	Q	R	øS	CH	T	U	V	
12	5÷25	23.5	13	6	5.5	28	26	11	32.5		6.5	10.5	3.7	6	3.7	7	38	M3	M5		8	5	2	9.5	16.5		
16	5÷25	28	20	8	7.5	33	28	11	33		6.7	10.5	3.7	6	3.7	10	37.5	M5	M5		20	8	7	2	10	19	
20	5÷25	32	22	10	9	37	32	11	32		6.5	10.5	4.6	7.5	4.6	10	36.5	M5	M5		22	8	8	2	11	21	
25	5÷25	37	26	10	9	47.5	39	18	33	36.5	8.5	8.5	4.6	7.5	4.6	10	42.5	20	M5	G1/8		28	15	8	2	14	28
32	5÷25	45	32	12	11	56	48	18	37	40.8	10	10	5.5	10	5.7	15	48.3	25	M6	G1/8		36	15	10	2.5	18	32
	>25÷50								45	48.8							56.3										
40	5÷25	54.5	40	12	11	62.7	54.5	18	39.5	44.7	10	10	5.5	10	5.7	15	53.2	30	M6	G1/8		40	15	10	2.5	20	35.5
	>25÷50								47.5	52.7							61.2										
50	5÷25	66	50	16	15	73	66	18	39.5	46.2	11	11	6.6	11	6.8	18	53.2	35	M8	G1/8		50	15	13	3.5	25	40
	>25÷50								47.5	54.2							61.2										
63	5÷25	80	62	16	15	88	80	23	42	48.7	12	12	9	15	9	18	57.7	35	M8	G1/8		62	15	13	3.5	31	48
	>25÷50								50	56.7							65.7										

COTES D'ENCOMBREMENT VERSIONS ANTI-ROTATION Ø 12

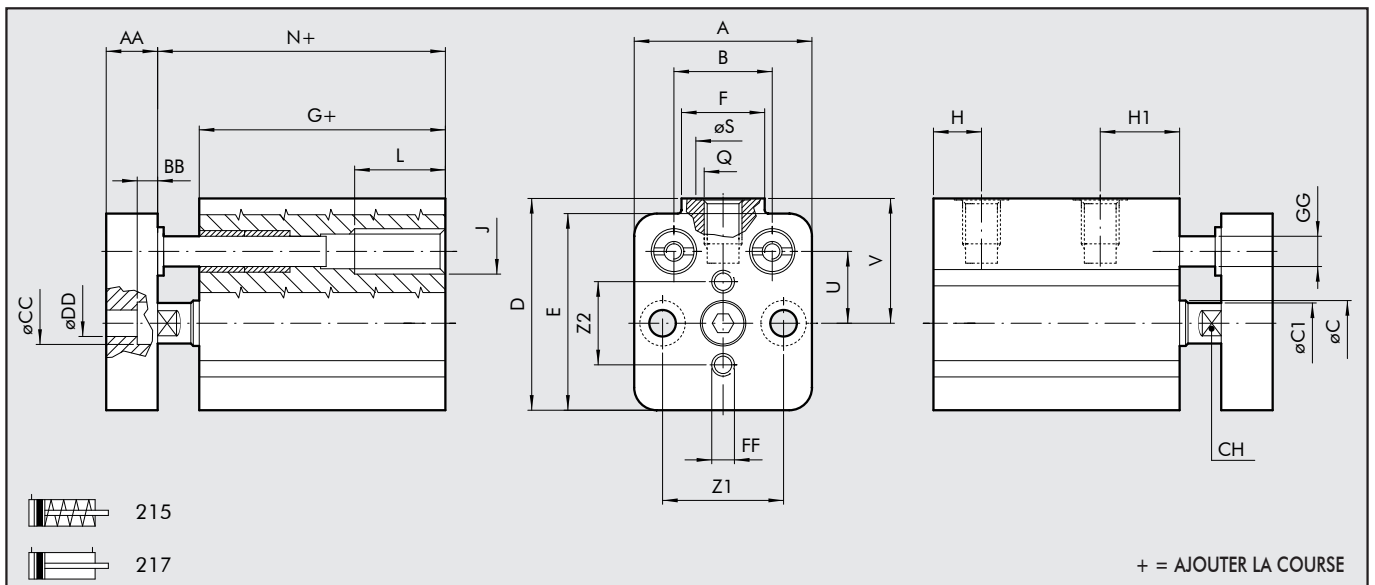

Ø	A	B	øC	øC ₁	D	E	F	G	H	H ₁	J	L	N	Z ₁	Z ₂	Q	øS	U	V	AA	BB	øCC	øDD	FF	øGG
12	23.5	13	6	5.5	28	26	11	32.5	6.5	10.5	M6	12	38	16	11	M5	8	9.5	16.5	8	3.5	6	3.5	M3	4

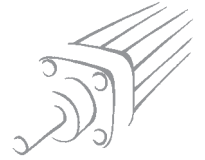

COTE D'ENCOMBREMENT VERSION ANTI-ROTATION Ø 16 ÷ 100

1

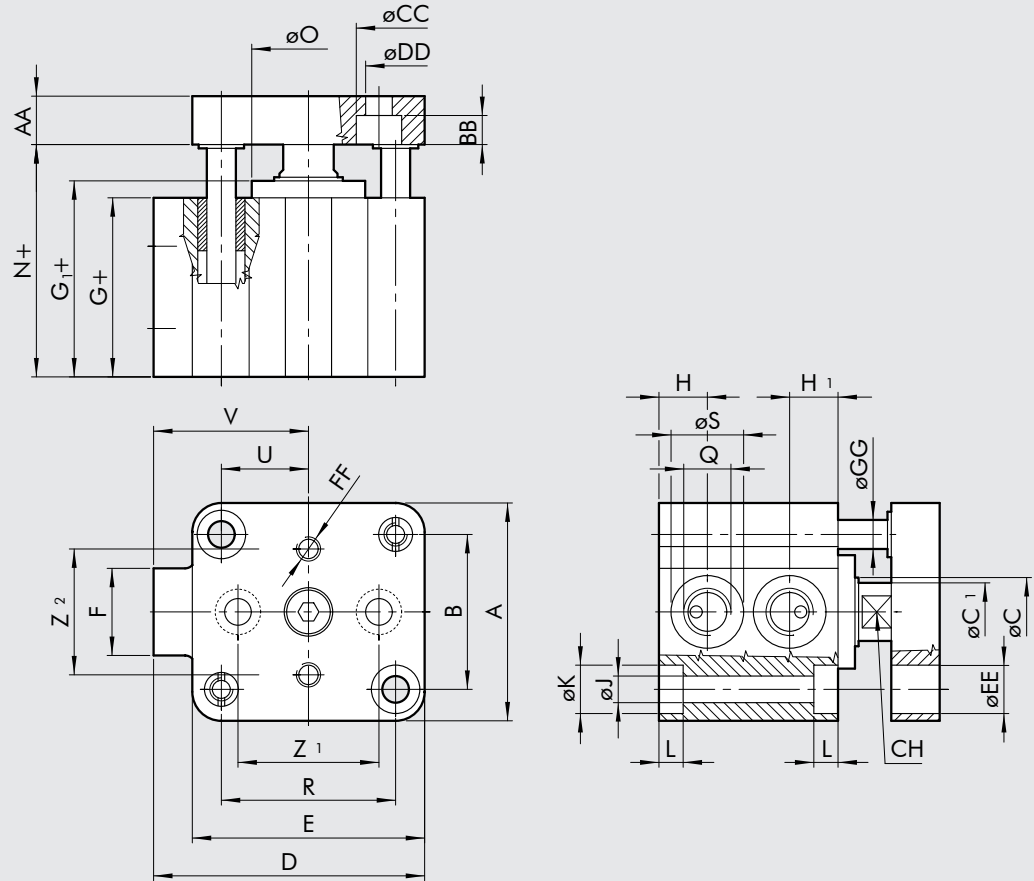

+ = AJOUTER LA COURSE

Ø	A	B	øC	øC ₁	D	E	F	G	G ₁	H	H ₁	J	K	L	N	Z ₁	Z ₂	Q	R	øS	CH	U
16	28	20	8	7.5	33	28	11	33		6.7	10.5	3.7	6	3.7	37.5	20	15	M5	20	8	7	10
20	32	22	10	9	37	32	11	32		6.5	10.5	4.6	7.5	4.6	36.5	22	18	M5	22	8	8	11
25	37	26	10	9	47.5	39	18	33	36.5	8.5	8.5	4.6	7.5	4.6	42.5	22	22	G1/8	28	15	8	14
32	45	32	12	11	56	48	18	37	40.8	10	10	5.5	10	5.7	48.3	26	26	G1/8	36	15	10	18
40	54.5	40	12	11	62.7	54.5	18	39.5	44.7	10	10	5.5	10	5.7	53.2	34	34	G1/8	40	15	10	20
50	66	50	16	15	73	66	18	39.5	46.2	11	11	6.6	11	6.8	53.2	43	43	G1/8	50	15	13	25
63	80	62	16	15	88	80	23	42	48.7	12	12	9	15	9	57.7	55	55	G1/8	62	15	13	31
80	100	82	20	19	110	100	26	57	67.2	14	14	9	15	9	75.2	70	70	G1/4	82	19	17	41
100	124	103	25	24	134	124	26	64	74.7	15	15	11	18	11	84.3	94	94	G1/4	103	19	22	51.5

Ø	V	AA	BB	øCC	øDD	øEE	FF	øGG	øO
16	19	8	3.5	6	3.5	6	M3	4	
20	21	8	5	7.5	4.5	7.5	M4	6	
25	28	8	5	7.5	4.5	8	M4	6	20
32	32	10	6	10	5.5	10	M5	8	25
40	35.5	10	6	10	5.5	10	M5	8	30
50	40	12	7	11	6.5	11	M6	10	35
63	48	12	9	14	9	15	M6	10	35
80	60	14	9	14	9	15	M8	12	44
100	72	17	9	14	9	18	M8	12	56

COTES D'ENCOMBREMENT VERSIONS TIGE TRAVERSANTE

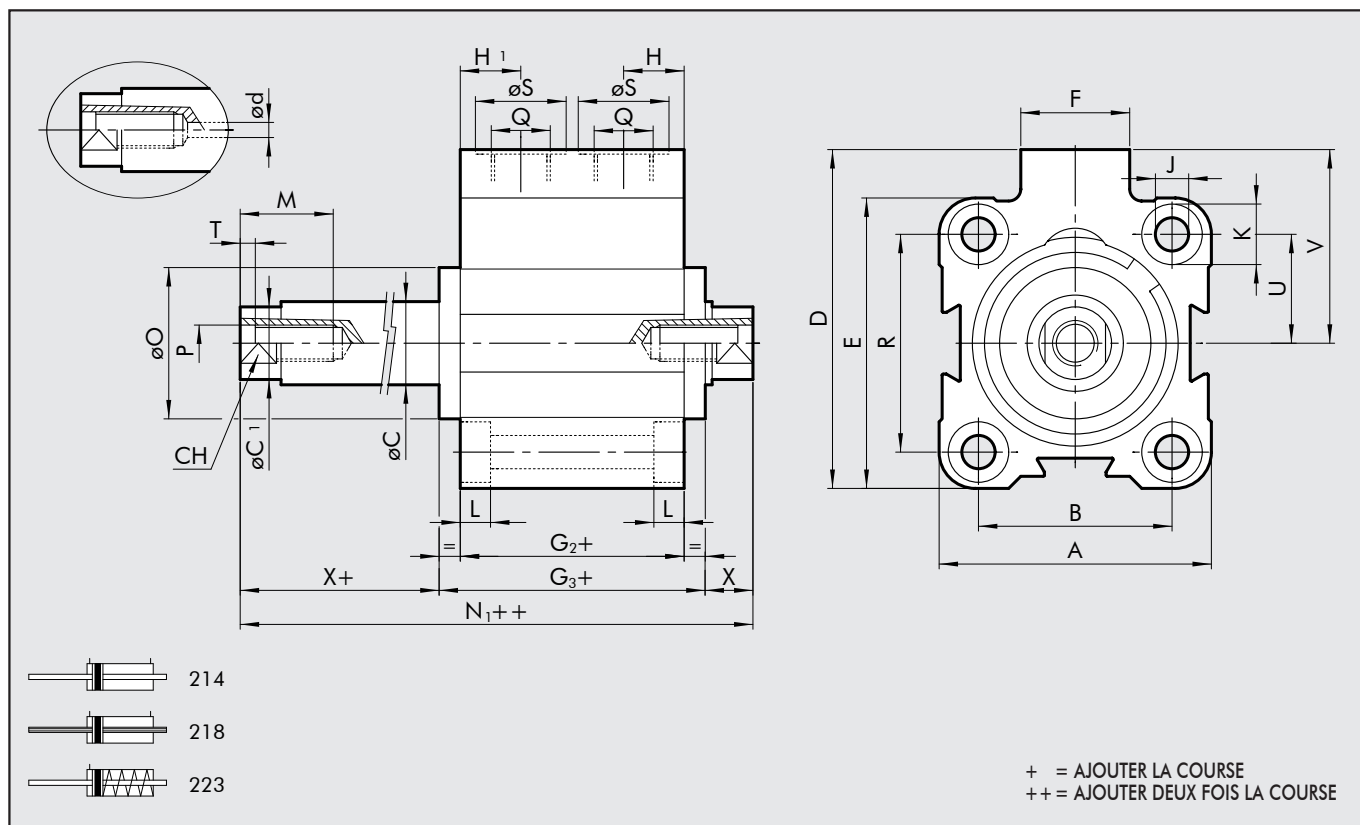

COTES D'ENCOMBREMENT VERSIONS DOUBLE EFFET TIGE TRAVERSANTE ET TIGE CREUSE

Ø	A	B	øC	øC ₁	D	ød**	E	F	G ₂	G ₃	H	H ₁	J	K	L	M	N ₁	øO	P	Q	R	øS	CH	T	U	V	X*
12	23.5	13	6	5.5	28		26	11	36.7		10.5	10.5	3.7	6	3.7	7	47.7	M3	M5		8	5	2	9.5	16.5	5.5	
16	28	20	8	7.5	33		28	11	36.8		10.5	10.5	3.7	6	3.7	10	45.8	M5	M5	20	8	7	2	10	19	4.5	
20	32	22	10	9	37	1.5	32	11	36		10.5	10.5	4.6	7.5	4.6	10	45.0	M5	M5	22	8	8	2	11	21	4.5	
25	37	26	10	9	47.5	1.5	39	18	35.7	42.7	8.5	8.5	4.6	7.5	4.6	10	54.7	20	M5	G1/8	28	15	8	2	14	28	6
32	45	32	12	11	56	2.5	48	18	37	44.5	10	10	5.5	10	5.7	15	59.5	25	M6	G1/8	36	15	10	2.5	18	32	7.5
40	54.5	40	12	11	62.7	2.5	54.5	18	39.5	49.9	10	10	5.5	10	5.7	15	66.9	30	M6	G1/8	40	15	10	2.5	20	35.5	8.5
50	66	50	16	15	73	2.5	66	18	39.5	52.9	11	11	6.6	11	6.8	18	66.9	35	M8	G1/8	50	15	13	3.5	25	40	7
63	80	62	16	15	88	4	80	23	42	55.4	12	12	9	15	9	18	73.4	35	M8	G1/8	62	15	13	3.5	31	48	9
80	100	82	20	19	110	5	100	26	57	77.4	14	14	9	15	9	18	93.4	44	M10	G1/4	82	19	17	4	41	60	8
100	124	103	25	24	134	6	124	26	64	85.4	15	15	11	18	11	20	104.6	56	M12	G1/4	103	19	22	5	51.5	72	9.6

*pour Ø12, Ø16, Ø20: (N₁++) = (G₂+) + (X) + (X+)

**de perçage uniquement pour la version tige creuse

COTES D'ENCOMBREMENT VERSIONS SIMPLE EFFET TIGE TRAVERSANTE

Ø	course	A	B	øC	øC ₁	D	E	F	G ₂	G ₃	H	H ₁	J	K	L	M	N ₁	øO	P	Q	R	øS	CH	T	U	V	X*
12	5÷25	23.5	13	6	5.5	28	26	11	36.7		10.5	10.5	3.7	6	3.7	7	47.7	M3	M5		8	5	2	9.5	16.5	5.5	
16	5÷25	28	20	8	7.5	33	28	11	36.8		10.5	10.5	3.7	6	3.7	10	45.8	M5	M5	20	8	7	2	10	19	4.5	
20	5÷25	32	22	10	9	37	32	11	36		10.5	10.5	4.6	7.5	4.6	10	45.0	M5	M5	22	8	8	2	11	21	4.5	
25	5÷25	37	26	10	9	47.5	39	18	35.7	42.7	8.5	8.5	4.6	7.5	4.6	10	57.7	20	M5	G1/8	28	15	8	2	14	28	6
32	5÷25	45	32	12	11	56	48	18	37	44.5	10	10	5.5	10	5.7	15	59.5	25	M6	G1/8	36	15	10	2.5	18	32	7.5
	>25÷50								45	52.5							67.5										7.5
40	5÷25	54.5	40	12	11	62.7	54.5	18	39.5	49.9	10	10	5.5	10	5.7	15	66.9	30	M6	G1/8	40	15	10	2.5	20	35.5	8.5
	>25÷50								47.5	57.9							74.9										8.5
50	5÷25	66	50	16	15	73	66	18	39.5	52.9	11	11	6.6	11	6.8	18	66.9	35	M8	G1/8	50	15	13	3.5	25	40	7
	>25÷50								47.5	60.9							74.9										7
63	5÷25	80	62	16	15	88	80	23	42	55.4	12	12	9	15	9	18	73.4	35	M8	G1/8	62	15	13	3.5	31	48	9
	>25÷50								50	63.4							81.4										9

*pour Ø12, Ø16, Ø20: (N₁++) = (G₂+) + (X) + (X+)

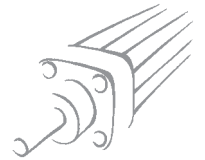

CLEFS DE CODIFICATION

CYL	2	1	2	0	4	0	0	0	1	0	C	P		
	TYPE			DIAMETRE		COURSE					TIGE	JOINTS		
208	■	Simple effet tige rentrée non magnétique	0	Magnétique	12	Pour les courses maximales, voir les Caractéristiques techniques					A	Tige acier chromé C45, piston aluminium pour Ø 12÷63 mm	P	Joint Polyuréthane
209	■	Simple effet tige sortie non magnétique	S	Non magnétique	16						N	Joint NBR		
210	■	Simple effet, tige rentrée	G▲	Basse vitesse	20						V●	Joint FKM/FPM		
211	■	Simple effet, tige sortie			25						B●	Joint Basse température		
212	■	Double effet, magnétique			32									
213	■	Double effet, non magnétique			40									
214	■	Double effet, tige traversante			50									
215	■	Simple effet, tige rentrée, anti-rotation			63									
217	■	Double effet, anti-rotation			80									
218	▼	Double effet, tige traversante creuse			◆ 100									
221		Avec fixation arrière mâle (Ø 32 à Ø 63)												
222		Avec fixation arrière femelle (Ø 32 à Ø 63)												
223	■	Simple effet, tige traversante												

- ◆ Lorsque la quatrième position est occupée par une lettre, remplacer 100 par A1
- Disponible pour Ø12 à Ø63
- ▼ Disponible pour Ø20 à Ø100
- Disponible uniquement pour les versions non magnétique (S) avec piston en aluminium (A ou Z)
- ▲ Non disponible pour les versions avec joints NBR

VERSION AVEC FIXATION ARRIERE FEMELLE CODE 222 Ø course D₂ G G₁ H₆ H₈ N R S₁ S₂

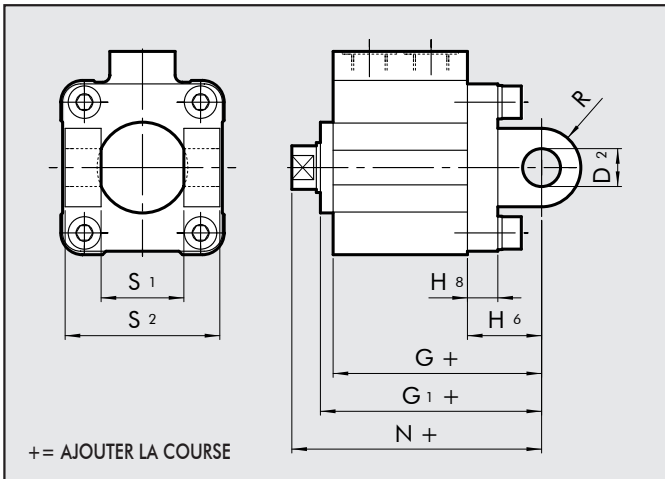

32	5÷70	10	59	62.8	22	10	70.3	11	26	45
40	5÷70	12	64.5	69.7	25	10	78.2	13	28	52
50	5÷110	12	66.5	73.2	27	12	80.2	13	32	60
63	5÷110	16	74	80.7	32	12	89.7	17	40	70

Nota: pour toutes les autres cotes d'encombrement, voir les versions standards

VERSION AVEC FIXATION ARRIERE MALE CODE 221 Ø course D₂ G G₁ H₆ H₈ N R S₁

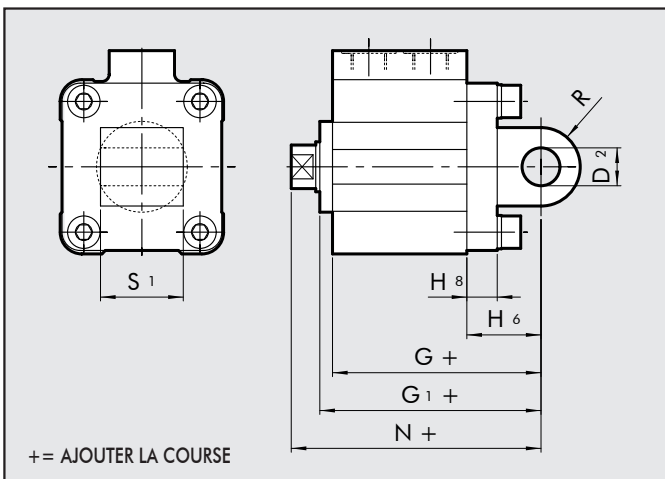

32	5÷70	10	59	62.8	22	10	70.3	11	26
40	5÷70	12	64.5	69.7	25	10	78.2	13	28
50	5÷110	12	66.5	73.2	27	12	80.2	13	32
63	5÷110	16	74	80.7	32	12	89.7	17	40

Nota: pour toutes les autres cotes d'encombrement, voir les versions standards

COTES D'ENCOMBREMENT DES EMBOUTS DE TIGE

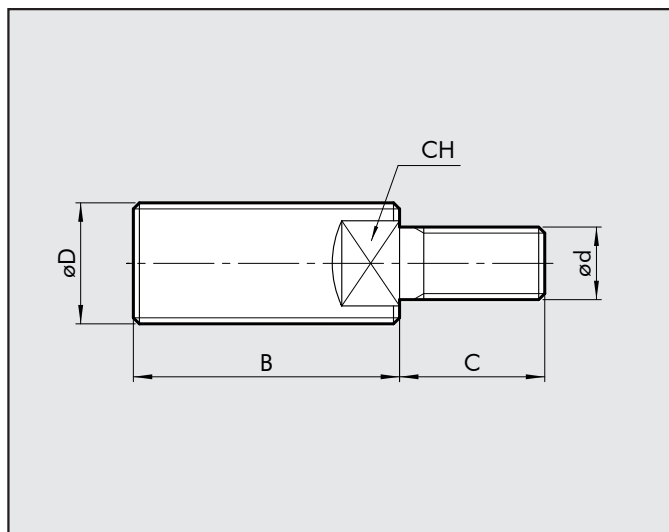

Code	Ø	Ø D	Ø d	B	C	CH	Poids [g]
219001200	12	M6	M3	16	6	4	3
219001600	16	M8	M5	20	9	6	8
219001600	20	M8	M5	20	9	6	8
219002500	25	M10x1.25	M5	22	9	7	12
219003200	32	M10x1.25	M6	22	12	7	14
219004000	40	M12x1.25	M6	24	12	10	14
219005000	50	M16x1.5	M8	32	15	13	20
219005000	63	M16x1.5	M8	32	15	13	20
219008000	80	M20x1.5	M10	40	15	17	96
219010000	100	M20x1.5	M12	40	18	17	102

PIECES DE RECHANGE POUR VERINS SSCY

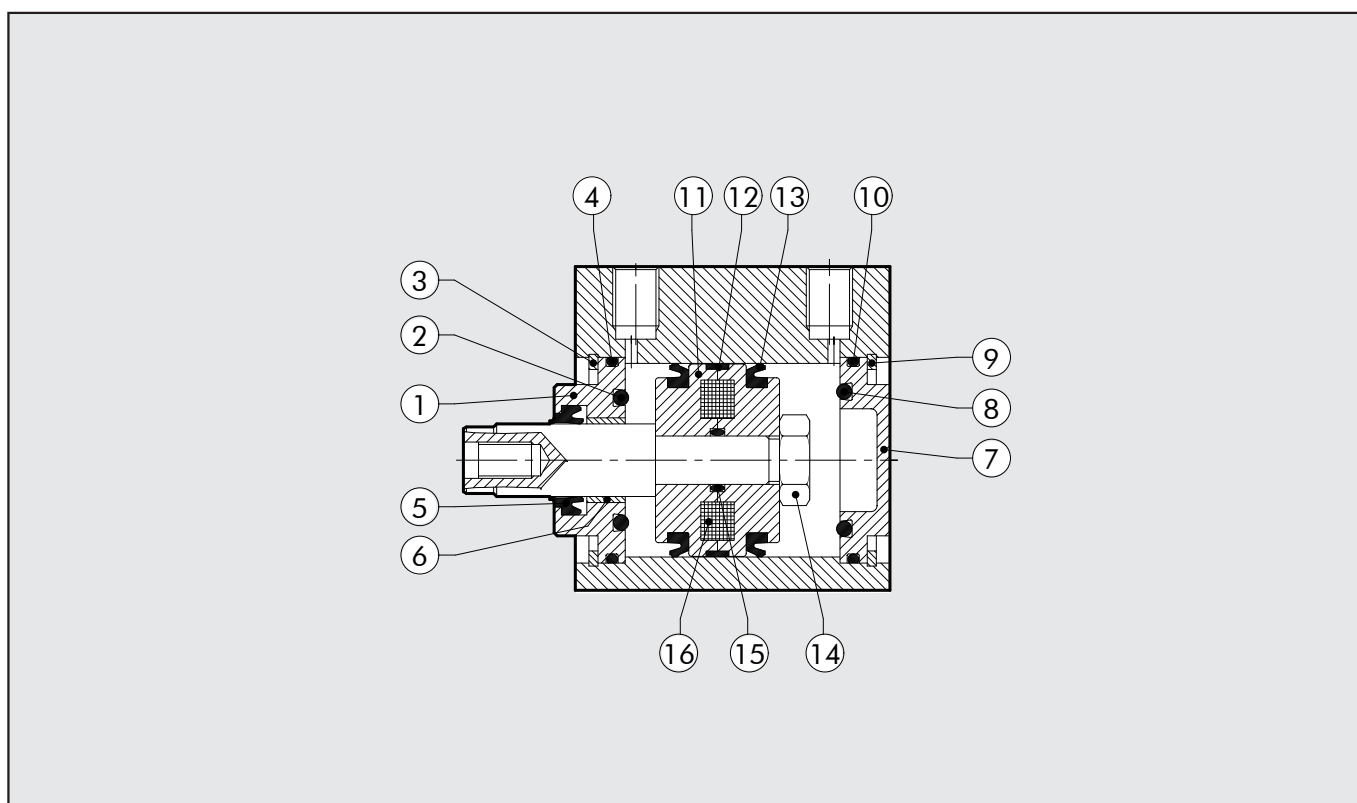

Type	Repères	Diamètre	Code
Kit fond avant complet avec joints Polyuréthane	1-2-3-4-5-6	Ø 12÷100	009 ... 0010
Kit fond avant complet avec joints NBR	1-2-3-4-5-6	Ø 12÷100	009 ... 0011
Kit fond arrière complet avec joints NBR	7-8-9-10	Ø 12÷100	009 ... 0015
Kit piston avec joints Polyuréthane	11-12-13-14-15	Ø 12÷100	009 ... 0021
Kit piston avec joints NBR	11-12-13-14-15	Ø 12÷100	009 ... 0023
Kit de joints Polyuréthane	2-4-5-8-10-13-15	Ø 12÷100	009 ... 0005
Kit de joints NBR	2-4-5-8-10-13-15	Ø 12÷100	009 ... 0006
Kit fond av. et arr. + piston avec joints Polyuréthane	1-2-3-4-5-6-7-8-9-10-11-12-13-14-15	Ø 12÷100	009 ... 0031
Kit fond av. et arr. + piston avec joints NBR	1-2-3-4-5-6-7-8-9-10-11-12-13-14-15	Ø 12÷100	009 ... 0033
Anneau magnétique	16	Ø 12÷100	009 ... 0001

Nota: Pour compléter les codes ajouter 3 chiffres pour le Ø (Ex. Ø 50:050)

